

SERVICE BULLETIN

TITLE: STABILIZERS - INSPECTION/REPLACEMENT OF ELEVATOR BALANCE WEIGHT ASSEMBLIES

SYNOPSIS OF CHANGE

This Service Bulletin has been revised to add a balance weight inspection every 100 flight hours. Airplanes that had the elevator balance weight assembly replaced during accomplishment of the original issue of this Service Bulletin will not be subject to this inspection. This inspection requirement terminates upon replacement of the elevator balance weight assembly. In addition, a note has been included under Paragraph 3.A(1) to indicate that elevator weights have been built to multiple type design revisions and may have five (5) inserts as shown in Figure 1 or four (4) inserts. Relevant technical changes are marked with change bars in the outside margins.

1. Planning Information

A. Effectivity

(1) Airplanes

Model 58, Baron, Serials TH-1768 through TH-2110.

If you are no longer in possession of the airplane, please forward this information to the present owner.

(2) Spares

Any Baron Model 58, 58TC, 58P, 95C55, E55, or 56TC with elevator balance weight assembly that was purchased between January 1, 1996 and December 31, 2005.

B. Reason

This Service Bulletin is being issued to inspect for proper installation of the existing elevator balance weight assemblies. The potential exists that the existing elevator balance weight assemblies are not sufficiently hardened in accordance with Hawker Beechcraft Corporation (HBC) standards. A balance weight assembly that is not sufficiently hardened may become misshapen and has the potential to become dislodged. This condition could result in an unbalanced elevator.

C. Description

This Service Bulletin provides instructions to inspect the existing elevator balance weight assemblies. Elevator balance weight assemblies that have become dislodged shall be replaced.

The export of these commodities, technology or software are subject to the U.S. Export Administration Regulations. Diversion contrary to U.S. law is prohibited. For guidance on export control requirements, contact the Commerce Department's Bureau of Export Administration at <http://www.bis.doc.gov>.

Hawker Beechcraft Corporation (HBC) issues Service Information for the benefit of owners and fixed base operators in the form of two classes of Service Bulletins. The first class, Mandatory Service Bulletins (red border) includes changes, inspection and modifications that could affect safety or crashworthiness. HBC also issues Service Bulletins with no red border which are designated as either recommended or optional in the compliance section within the bulletin. In the case of recommended Service Bulletins, HBC feels the changes, modifications, improvements or inspections will benefit the owner/operator and although highly recommended, Recommended Service Bulletins are not considered mandatory at the time of issuance. In the case of Optional Service Bulletins, compliance with the changes, modifications, improvements or inspections is at the owner/operator's discretion.

Both classes are available on the web at <http://pubs.hawkerbeechcraft.com> and mailed to:

- (a) Owners of record on the FAA Aircraft Registration Branch List and the HBC Safety of Flight Information (SOFI) List.
- (b) Those having a publications subscription.

Information on Safety of Flight Information (SOFI) or subscription can be obtained through the Hawker Beechcraft Corporation Technical Manual Distribution Center (TMDC). As Mandatory Service Bulletins and Service Bulletins are issued, the Service Bulletin Master Index will be updated and available online at <http://pubs.hawkerbeechcraft.com>. Warranty will be allowed only when specifically defined in the Service Bulletin and in accordance with HBC Warranty Policy.

Unless otherwise designated, HBC Mandatory Service Bulletins, Service Bulletins and HBC Kits are approved for installation on HBC airplanes in original or HBC modified configurations only. HBC Mandatory Service Bulletins, Service Bulletins and Kits may not be compatible with airplanes modified by STC installations or modifications other than HBC approved kits.



SERVICE BULLETIN

D. Compliance

An Airworthiness Directive will be requested on the matter covered by this Service Bulletin.

Hawker Beechcraft Corporation considers this to be a Mandatory Service Bulletin. The original issue of this Service Bulletin must be accomplished prior to next flight. Airplanes that have not had the elevator balance weight assembly replaced during accomplishment of the original issue of this Service Bulletin shall be subject to an inspection every 100 flight hours. This inspection requirement will terminate upon replacement of the elevator balance weight assembly.

E. Approval

The engineering data contained in this Service Bulletin is FAA approved.

Prior to accomplishment, owners/operators of airplanes registered in countries other than the United States shall consult with their local Aviation Regulatory Authority.

Incorporation of this Service Bulletin restores the airplane to original Type Design.

F. Manpower

The following information is for planning purposes only:

Estimated man-hours for inspection: 1 hour

Estimated man-hours for replacement: 5 hours per side

Suggested number of technicians: 1

The above is an estimate based on experienced, properly equipped technicians complying with this Service Bulletin.

G. Weight and Balance

Negligible.

It is the responsibility of the owner/operator to maintain compliance with the applicable Airworthiness Regulations.

H. Electrical Load Data

No change.

I. Software Accomplishment Summary

Not applicable.

J. References

Baron Maintenance Manual (MM), P/N 55-590000-13G3 or subsequent revision, Chapter 20-15-00, Chapter 27-30-00, and Chapter 51-60-00.

K. Publications Affected

None.

L. Interchangeability of Parts

Not applicable.

SERVICE BULLETIN

M. Warranty Credit

Warranty credit for labor and parts to the extent noted under MANPOWER and MATERIAL will be allowed on all affected airplanes that are under standard warranty coverage on the date of issuance of this Service Bulletin. Credit will be given for any airplanes that have an active HBC Maintenance Program for labor and parts, if coverage is active and the work is accomplished prior to the warranty expiration date listed in this Service Bulletin. Claims for compliance with this Service Bulletin are to be filed as a W3-type claim against SB 55-4089, Revision 1.

Warranty coverage offered in this Service Bulletin will expire 12 months from the last day of the month Revision 1 of this Service Bulletin is issued. After this date, the owner/operator assumes the responsibility for compliance cost. Hawker Beechcraft Corporation (HBC) reserves the right to void continued warranty coverage in the area affected by this Service Bulletin until the date the Service Bulletin is accomplished by an HBC Authorized Service Center (ASC).

The owner/operator should contact an HBC ASC to schedule the warranty work to be accomplished. The HBC ASC must be rated to perform maintenance on the specific model of Hawker Beechcraft airplane. The HBC ASC will submit the appropriate paperwork directly to the HBC Warranty Department for warranty consideration. In the event that work cannot be accomplished at an HBC ASC, parts may be purchased directly from Hawker Beechcraft Parts & Distribution (HBP&D) and a warranty claim for parts ONLY should be submitted directly to the HBC Warranty Department.

After the Service Bulletin has been accomplished, a warranty claim must be submitted to HBC within 60 days of the Service Bulletin completion date.

2. Material Information

A. Materials - Price and Availability

Contact information:

Hawker Beechcraft Parts & Distribution (HBP&D)

10511 East Central Avenue

Wichita, KS 67206

USA

Phone: 316-676-3100 or 1-888-727-4344

Fax: 316-676-3222 or 316-676-3327

E-mail: HBC_Parts@hawkerbeechcraft.com

B. Industry Support

Not applicable.

SERVICE BULLETIN

C. Airplanes

- (1) The following parts, required for accomplishment of this Service Bulletin, may be ordered through a Hawker Beechcraft Authorized Service Center or HBP&D:

Part Number	Description	Quantity Per Airplane
96-610022-5	Elevator Balance Weight Assembly	As Required
96-610022-7	Elevator Balance Weight Assembly	As Required
96-610022-9	Elevator Balance Weight Assembly	As Required
96-610022	Elevator Balance Weight Assembly	As Required

Hawker Beechcraft Corporation expressly reserves the right to supersede, cancel and/or declare obsolete, without prior notice, any parts or publications that may be referenced in this Service Bulletin.

- (2) The following materials may be obtained locally:

Maintenance Manual Chapter or Part Number	Description	Quantity Per Airplane
Maintenance Manual Chapter 20-15-00	Paint, Urethane	As Required
MS24694-S4	Screw	As Required
AN936D8 or MS35790-9	Washer	As Required

D. Spares

Refer to spares notations in Paragraphs 1.A and 3.B of this Service Bulletin.

E. Reidentified Parts

None.

F. Tooling - Price and Availability

Not applicable.

SERVICE BULLETIN

3. Accomplishment Instructions

This Service Bulletin shall be accomplished as follows:

NOTE

Should any difficulty be encountered in accomplishing this Service Bulletin, contact Hawker Beechcraft Corporation at 1-800-429-5372 or 316-676-3140.

WARNING

Observe all Warnings and Cautions contained in the airplane manuals referenced in this Service Bulletin.

Whenever any part of this system is dismantled, adjusted, repaired or renewed, detailed investigation must be made on completion to make sure that distortion, tools, rags or any other loose articles or foreign matter that could impede the free movement and safe operation of the system are not present, and that the systems and installations in the work area are clean.

A. Airplane

- (1) Remove all power from the airplane and disconnect the battery. Display warning notices prohibiting reconnection of airplane electrical power.

NOTE

The following steps apply to the left and right elevator balance weight assemblies.

NOTE

Elevator weights have been built to multiple type design revisions and may have five (5) inserts as shown in Figure 1 or four (4) inserts.

- (2) Gain access to the elevator and locate the existing elevator balance weight assembly that is installed under the elevator horn skin. Refer to Figure 1 and Figure 2.
- (3) Visually inspect to determine if the existing elevator balance weight assembly is in position and protruding from the edge of the rib. In addition, verify that the elevator balance weight assembly attachment screws on upper and lower surfaces are secure and the installation holes show no sign of discoloration. Refer to Figure 1 and Figure 2.
 - (a) If the existing elevator balance weight assembly is in position, protruding from the edge of the rib, the attachment screws are secure and the installation holes show no sign of discoloration, no further action is required for this Service Bulletin. Proceed to Step (13).
 - (b) If the existing elevator balance weight assembly has become dislodged, the attachment screws are not secure, or the installation holes show signs of discoloration, proceed to Step (4).
- (4) Remove the existing screws and associated attachment hardware from the elevator horn skin. Retain the removed screws and associated attachment hardware.

SERVICE BULLETIN

- (5) Remove the existing elevator balance weight assembly from its position under the elevator horn skin.
- (6) Weigh the removed elevator balance weight assembly to determine which replacement elevator balance weight assembly shall be installed. Part numbers apply to the weight of the removed elevator balance weight assembly as follows:

Elevator balance weight assembly, P/N 96-610022 = 3.4 +/- 0.10 LB
Elevator balance weight assembly, P/N 96-610022-5 = 3.55 +/- 0.10 LB
Elevator balance weight assembly, P/N 96-610022-7 = 3.9 +/- 0.10 LB
Elevator balance weight assembly, P/N 96-610022-9 = 4.10 +/- 0.05 LB
- (7) Use the screws and associated attachment hardware that were retained in Step (4) to install the applicable new elevator balance weight assembly. **Note:** New hardware may be used as necessary, as defined in Paragraph 2.C.2. The installed elevator balance weight assembly shall protrude from the rib as shown in Figure 2.
- (8) Touch-up paint as necessary in accordance with Maintenance Manual (MM), Chapter 20-15-00. In addition, observe practices for painting the elevator that are defined in MM Chapter 51-60-00.
- (9) Remove the elevator in accordance with MM Chapter 27-30-00.
- (10) Perform elevator control surface balancing procedure in accordance with MM Chapter 51-60-00.
- (11) Install the elevator in accordance with MM Chapter 27-30-00.
- (12) Tag, mark, and dispose of the removed elevator balance weight assembly.
- (13) Reconnect the airplane battery, remove warning notices, and restore power.
- (14) Ensure all work areas are clean and clear of tools and miscellaneous items of equipment.
- (15) Return airplane to service.

B. Spares

Purge spares stock of any Baron elevator balance weight assembly [defined in Paragraph 1.A.(2)] that was purchased between January 1, 1996 and December 31, 2005. Tag, mark and dispose of the purged elevator balance weight assembly.

C. Record of Compliance

Upon completion of this Service Bulletin, make an appropriate maintenance record entry.

SERVICE BULLETIN

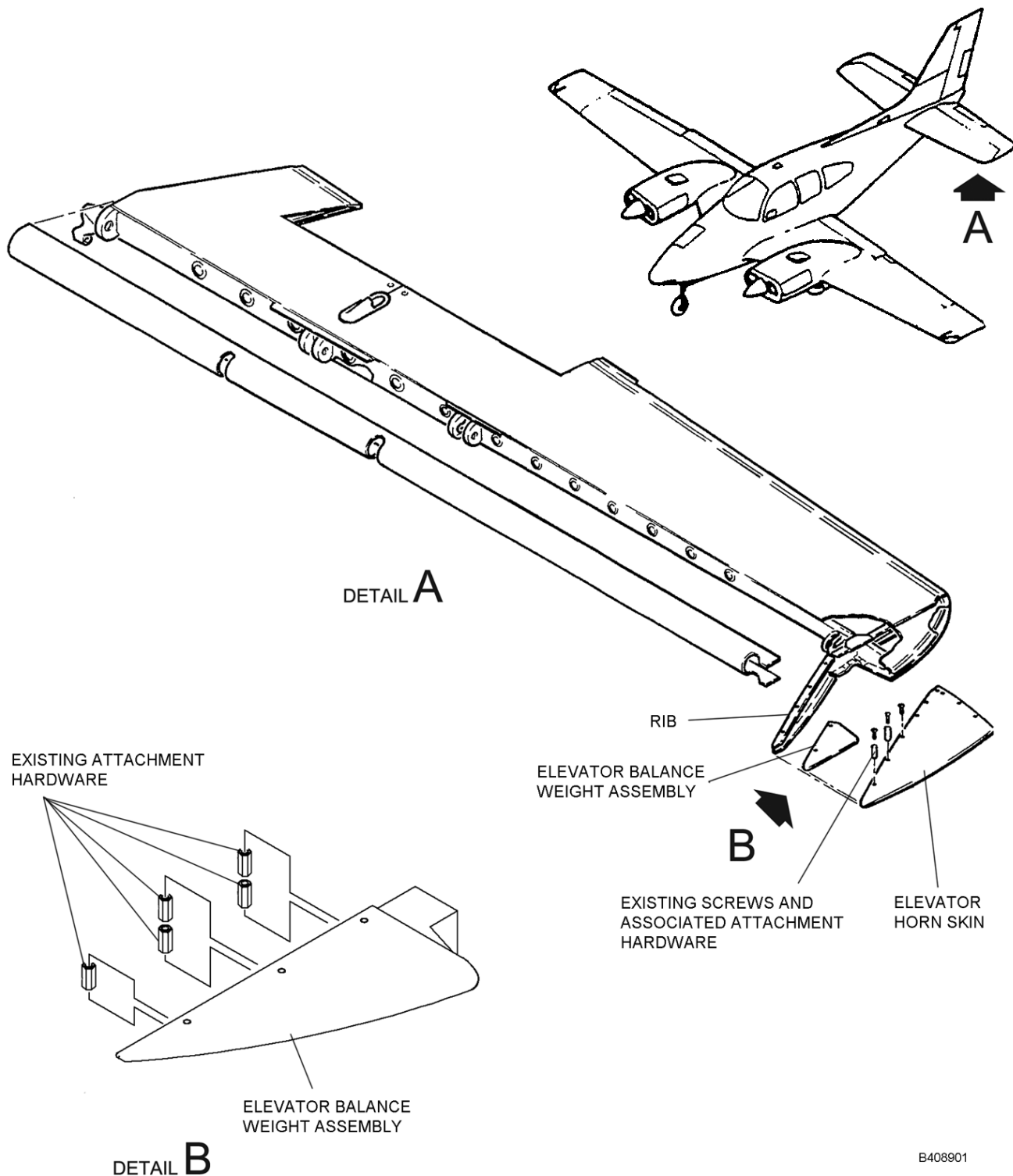

Inspection of Elevator Balance Weight Assembly
Figure 1

SERVICE BULLETIN

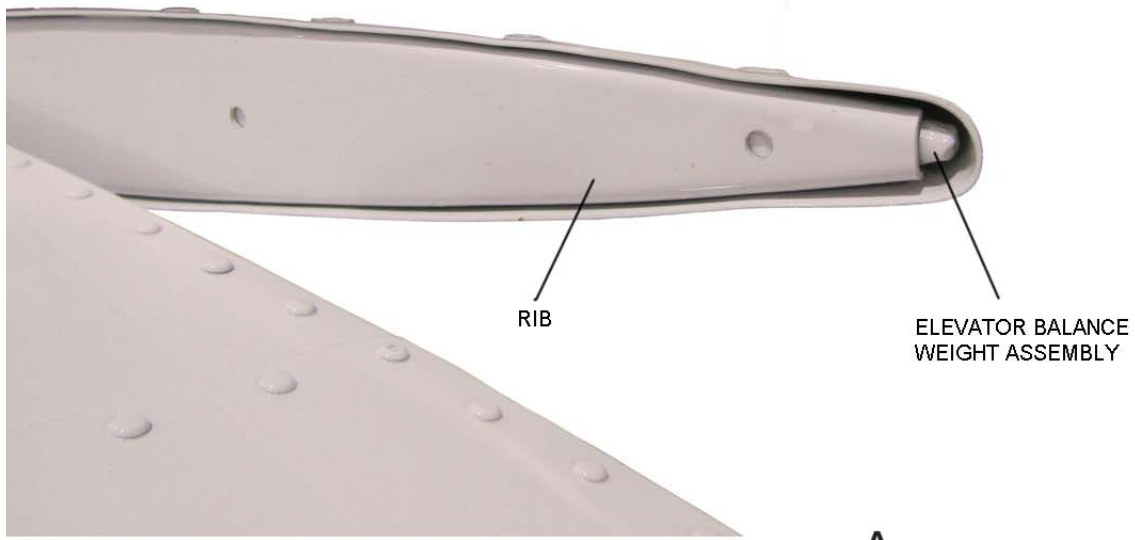
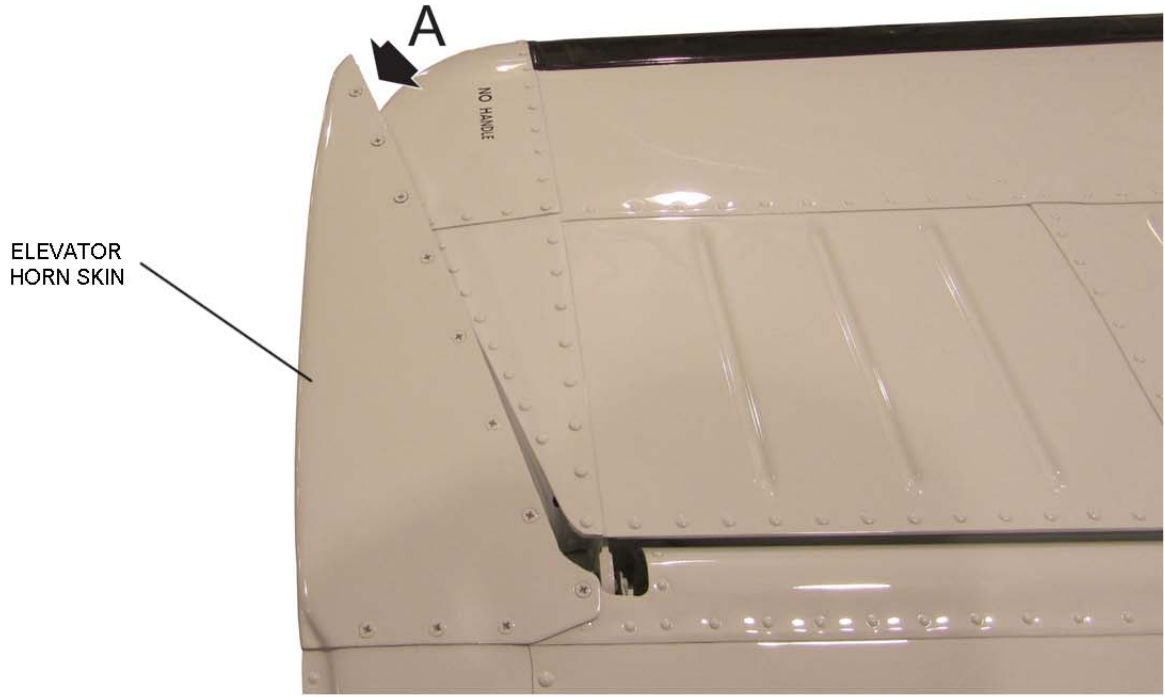

DETAIL A

B4089-02

Inspection of Elevator Balance Weight Assembly
Figure 2